

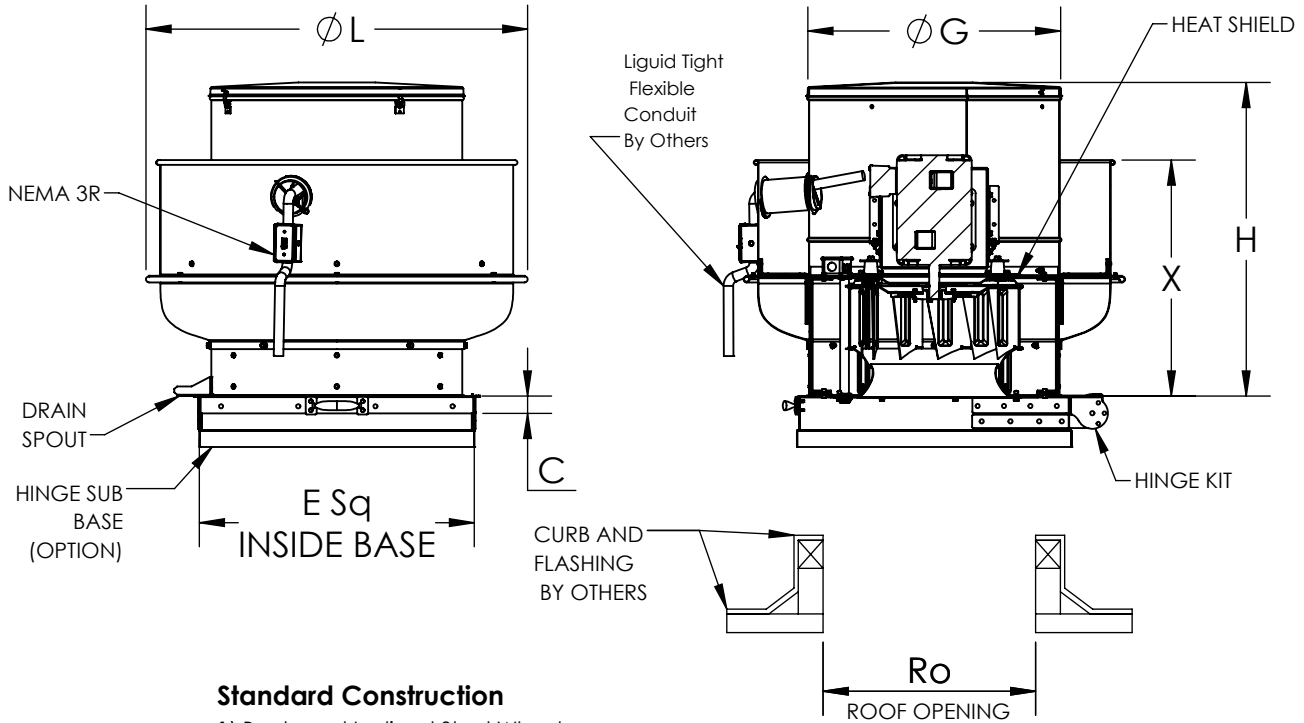

DATE: TAG:  
 JOB:  
 PROJECT:  
 COMPANY:  
 SALES PERSON:

PRU-DD (GREASE EXHAUST FAN)  
 POWER ROOF VENTILATOR - BELT DRIVE



**Standard Construction**

- 1) Backward Inclined Steel Wheel
- 2) Alum housing with Alum Curb Cap & Venturi
- 3) Galvanized motor structure with lifting lug
- 4) Drain Spout
- 5) Pre-wired switch NEMA 3R
- 6) High Temp. Paint for Wheel
- 7) Floating Hinge Kit
- 8) Heat shield (Insulation)

**Options & Accessories**

- 1) Hinge sub-base
- 2) Pedestal (Vented & Non-Vented)
- 3) Bird screen/Outlet Guard
- 4) Back Drafft & Control Damper
- 5) Extended lube lines
- 6) Curb Adaptor
- 7) Grease Collector

**DIMENSIONAL DATA**

SIZES	PARTIAL WIDTH 'X'					L	H	G	E	C	Ro	MAX MTR FRAME	MAX RPM	MAX WT. (lbs)
	110%	100%	80%	50%	30%									
060	-	14 15/16	-	-	-	25 1/4	21 1/2	16 1/4	17 1/8	1 13/16	9 1/2	48	1750	41
070	-	14 15/16	-	-	-	25 1/4	21 1/2	16 1/4	17 1/8	1 13/16	9 1/2	48	1750	42
080	-	14 15/16	-	-	-	25 1/4	21 1/2	16 1/4	17 1/8	1 13/16	9 1/2	48	1750	43
100	-	14 15/16	-	-	-	25 1/4	21 1/2	16 1/4	17 1/8	1 13/16	9 1/2	48	1750	40
122	-	18 1/8	-	-	-	30 1/4	24 1/2	19 3/4	21	1 13/16	13 1/2	48	1845	52
135	-	19 1/4	18 5/16	-	-	30 1/4	25 5/16	19 3/4	21	1 13/16	13 1/2	145T	1750	55
150	-	20 3/4	19 11/16	-	-	33 1/4	26 1/4	21 7/8	23 3/8	1 13/16	16	145T	1845	62
165	22 5/16	21 3/4	20 9/16	18 7/8	-	36 1/4	29	24 1/8	25 5/8	1 13/16	18	145T	1805	72
182	24 11/16	24 1/16	22 3/4	20 7/8	-	39 3/4	32 9/16	26 5/8	28 3/8	1 13/16	21	184T	1565	85
200	25 3/4	25 1/16	23 11/16	21 9/16	-	43 1/4	33 13/16	29 1/8	31 1/8	1 13/16	23 1/2	184T	1325	96
222	28 3/4	27 15/16	26 3/8	24 1/16	-	47 3/4	35 7/8	32 1/4	34 9/16	1 13/16	27 1/2	184T	1250	115
245	30 13/16	29 15/16	28 3/16	25 5/8	23 7/8	47 3/4	37 5/16	32 1/4	34 9/16	1 13/16	27 1/2	184T	1175	133
270	34 3/16	33 1/4	31 5/16	28 1/2	26 9/16	52 3/8	39 3/4	35 1/2	38 1/4	1 13/16	31	215T	1103	153
300	35 5/16	34 1/4	32 1/8	28 15/16	26 7/8	57 3/4	41 3/4	39 3/8	42 1/2	1 13/16	35	215T	1030	177

ALL DIMENSIONS ARE IN INCHES, WEIGHTS ARE APPROXIMATE AND DOES NOT INCLUDE DRIVES OR ACCESSORIES.

REVISION:

FORM:

REPLACES: